



**RECHNER**

**Specialist for Level Control**

**Binary & of Ink**

**Analogue**





For all transactions, the newest version of the „General Conditions of Sale and Delivery for Products and Services of the Electrical Industry ZVEI“ shall apply, along with the supplementary conditions „extended reservation of proprietary rights“, together with the supplements listed on our order confirmations and/or invoices.

All specifications are subject to change without notice. Reprint, even in part, only with our consent.

© RECHNER Germany 09/2018 EN - Printed in EU, all rights reserved.

**Edition January 2020**

In this Brochure we show  
a selection of products used  
for level control on printing  
machines

Classic Capacitive Sensors  
Page 9 - 19

Capacitive Level Probes  
I-Level  
Page 20 - 26

## **Specialist for level control of inks**

*Sensors made for  
You!*



## Capacitive sensors and level probes are the perfect signal indicators for the level control of inks.

### CLASSIC CAPACITIVE SENSORS

generate a capacitive field in the active surface of the sensor. All liquids with a dielectric constant  $\epsilon_r > 1.1$  will be detected and dependent on the model used the sensor will give a digital or analogue signal, so that the level can be controlled via the subsequent electronics.

Classic capacitive sensors offer the following options:

- **Binary measurement**
- **Analogue Measurement**  
4...20 mA or 0...10 V

### CAPACITIVE LEVEL PROBES I-LEVEL

The capacitive level probes of the i-Level series are based on RECHNER's patented 3-electrode measuring principle. With this principle 2 electrodes are integrated in the probe and the 3rd electrode is formed by the metal container. Herewith the maximum possible measuring field is achieved.

The i-Level probes offer the following options:

- **Analogue Measurement**  
4...20 mA or 0...10 V
- **Binary Measurement** with
  - 1 Switching point
  - 2 Switching points (MIN/MAX)

## Application examples for capacitive sensors and level probes

### IN THE PRINT HEADS

The capacitive level sensors and probes ensure that the printing process works perfectly.

- Continuous level control
- Level measurement MIN/MAX
- Level regulation, in order to keep a defined level constant.

Container can be without pressure, pressurized or under vacuum.



### IN THE STORAGE CONTAINER

The capacitive level sensors control and indicate that the storage container is refilled or exchanged on time.

### LEVEL CONTROL THROUGH THE CONTAINER WALL

EasyMount Sensors measure the level of inks through the wall of the plastic container.

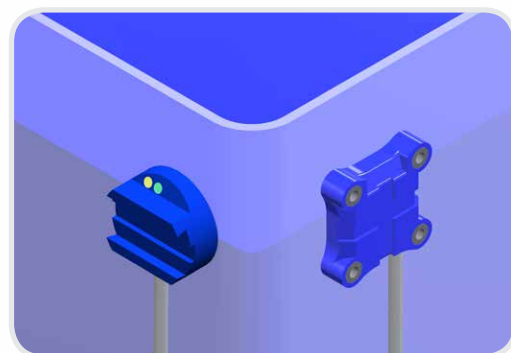

EasyMount Sensor round or rectangular

## Capacitive Level Sensors

**i-LEVEL**

Capacitive filling level sensors of the i-Level series in small dimensions for use in small containers.

The probe reliably detects liquids, pastes or powders.

For binary measurement, dependent on the model available with 1 or 2 switching points.

*Binary  
1 or 2  
Switching Points*



Capacitive filling level sensors of the i-Level series in small dimensions for use in small containers.

The sensor is designed for analogue level control of liquids, pastes or powders.

Output functions available are:  
0...10 V or 10...0 V,  
4...20 mA or 20...4 mA.



*Analogue*

# *Our Experience Your Advantage!*

Capacitive level measurement is our core competence.

We have decades of experience in level control in printing machines. For this reason we have a wide program of suitable sensors. It will be a pleasure for us, to develop the perfect sensor for your printing machine:

- Customer and application oriented.
- Sensors manufactured according to wishes and specifications.
- Special designs even in small quantities.

## **CAPACITIVE SENSORS DETECT ALL KINDS OF INKS:**

- **WATER BASED**
- **SOLVENT BASED**
- **UV - INKS**

# LevelMaster

*Binary or  
Analogue*







## Capacitive Sensors Series 80 - PNP

Housing M 8 x 1

- Housing material: PEEK (FDA 21 CFR 177.2415)
- Sensing distance 0.5...4 mm adjustable with 270° potentiometer
- With flange connector M 8 x 1



<b>Technical data</b>	Non-flush mountable
Operating distance $S_n$	2 mm
Operating distance min. / max. adjustable	0.5...4 mm
Electrical version	3 pin DC
Output function	Normally open
<b>Type PNP</b>	<b>KAS-80-A21-S-M8-PEEK-Y7-1-HP</b>
<b>Art.-No.</b>	<b>KA 1380</b>
Operating voltage ( $U_B$ )	10...35 V DC
Voltage drop max. ( $U_d$ )	≤ 2.0 V
Permitted residual ripple max.	10 %
Operating current ( $I_e$ )	0...150 mA
No-load current ( $I_o$ )	Typ. 15 mA
Frequency of operating cycles max.	50 Hz
Permitted ambient temperature	-25...+70 °C
LED-display	Yellow
Protective circuit	Built-in
Degree of protection IEC 60529	IP 67*
Norm	EN 60947-5-2
Connection	Flange connector M 8 x 1
Housing material	PEEK (FDA 21 CFR 177.2415)
Active surface	PEEK (FDA 21 CFR 177.2415)
<b>Accessories</b> (is delivered with the sensor)	2 nuts M 8 x 1
For matching connectors please see our selection of accessories.	

\* With sealed potentiometer screw

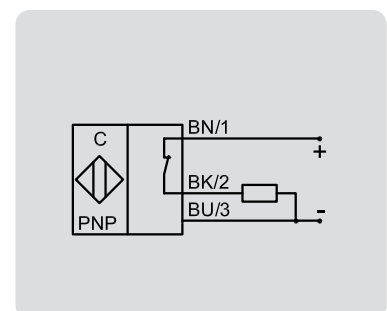
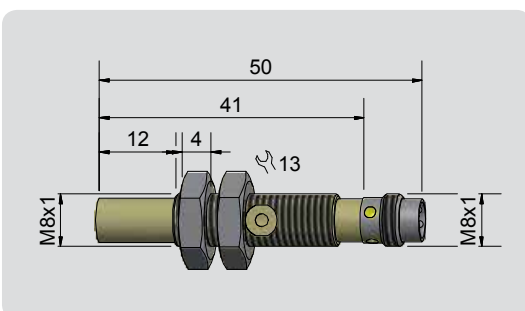

**Made in Germany**

All specifications are subject to change without notice. (14.01.2020)

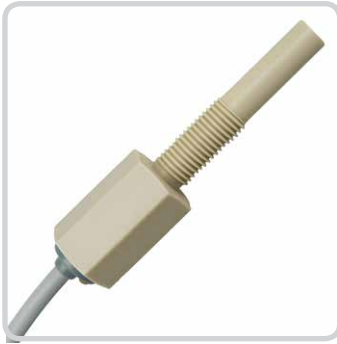

## Capacitive Sensors Series 80 - PNP

Housing M 8 x 1

- Housing material: PEEK (FDA 21 CFR 177.2415)
- Level control

With manufacturer certificate

for use in zone 22

Ex II 3D Ex mc IIIC T101°C Dc IP67 X



<b>Technical data</b>	Non-flush mountable
Level sensor, in contact with the product	Medium dependent
Electrical version	3 wire DC
Output function	Normally open
<b>Type PNP</b>	<b>KAS-80-A21/61-S-K-PEEK-3D</b>
<b>Art.-No.</b>	<b>KA 1420</b>
Operating voltage ( $U_B$ )	10...35 V DC
Voltage drop max. ( $U_D$ )	≤ 2.0 V
Permitted residual ripple max.	10 %
Operating current ( $I_B$ )	0...150 mA
No-load current ( $I_0$ )	Typ. 15 mA
Frequency of operating cycles max.	50 Hz
Permitted ambient temperature	-25...+70 °C
LED-display	Yellow
Protective circuit	Built-in
Degree of protection IEC 60529	IP 67*
Norm	EN 60947-5-2
Connection cable	2 m, PUR, 3 x 0.14 mm <sup>2</sup>
Housing material	PEEK (FDA 21 CFR 177.2415)
Active surface	PEEK (FDA 21 CFR 177.2415)
Lid	PA / PPO
Media optimized	Yes

\* With sealed potentiometer screw

All specifications are subject to change without notice. (14.01.2020)

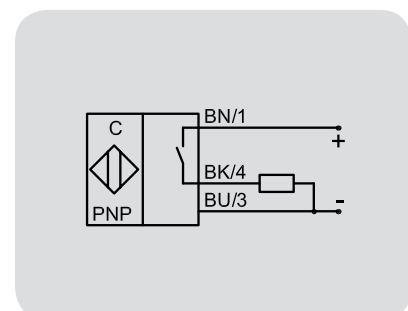
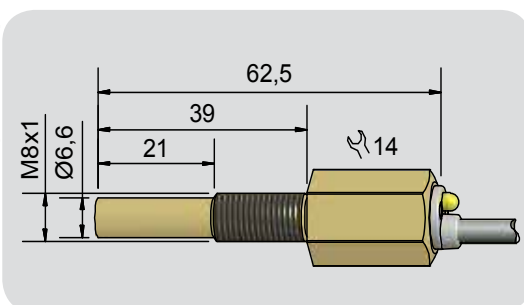

**Made in Germany**



## Capacitive Sensors Series 83 - PNP

Housing M 8 x 1

- Housing material: PEEK (FDA 21 CFR 177.2415)
- Level controll of liquids



<b>Technical data</b>	Non-flush mountable
Level sensor, in contact with the product	Medium dependent adjustable
Electrical version	3 wire DC
Output function	Normally closed
<b>Type PNP</b>	<b>KAS-83-A21/63-Ö-M8-PEEK-Z02-1-HP</b>
<b>Art.-No.</b>	<b>KA 1455</b>
Operating voltage ( $U_B$ )	10...35 V DC
Voltage drop max. ( $U_d$ )	≤ 2.0 V
Permitted residual ripple max.	10 %
Operating current ( $I_B$ )	0...150 mA
No-load current ( $I_0$ )	Typ. 15 mA
Frequency of operating cycles max.	50 Hz
Permitted ambient temperature	-25...+70 °C
LED-display	Green / yellow
Protective circuit	Built-in
Degree of protection IEC 60529	IP 67*
Norm	EN 60947-5-2
Connection	2 m, PUR 3 x 0,14mm <sup>2</sup>
Housing material	PEEK (FDA 21 CFR 177.2415)
Active surface	PEEK (FDA 21 CFR 177.2415)
Lid	PA / PPO
Media optimized	Yes

\* With sealed potentiometer screw

All specifications are subject to change without notice. (14.01.2020)

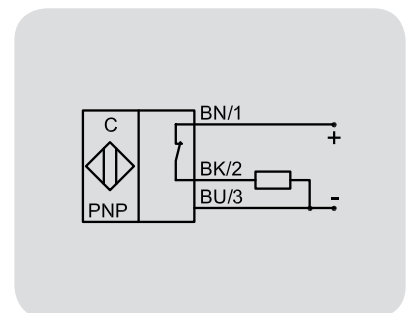
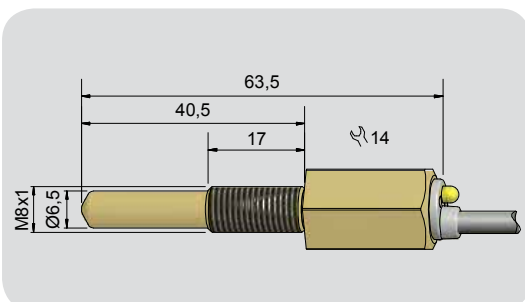

**Made in Germany**

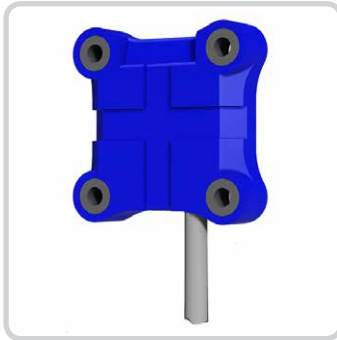

## Capacitive Sensors Series 80 - PNP **EasyMount**

Housing 34 x 34 mm  
Capacitive sensor for level control of liquids, very suitable for a measurement through non-metallic container walls. Special adaptation for bypass applications.

- Sensitivity adjustment with EasyTeach by magnet (ETM)  
Magnet delivered with the sensor
- Housing material: PA / PBT
- Easy to mount, by screwing, gluing or cable ties
- Watertight
- Flat housing - 8 mm



<b>Technical data</b>	Flush mountable
Operating distance $S_n$	5 mm
Operating distance min. / max. programmable	0...10 mm
Electrical version	3 wire DC
Output function	Normally open
<b>Type PNP</b>	<b>KAS-80-C30EM/8-S-34x34x8-PA-Z02-ETM-HP</b>
<b>Art.-No.</b>	<b>KA 1451</b>
Operating voltage ( $U_B$ )	10...35 V DC
Voltage drop max. ( $U_g$ )	≤ 2.0 V
Permitted residual ripple max.	10 %
Operating current ( $I_e$ )	0...200 mA
No-load current ( $I_o$ )	Typ 15 mA
Frequency of operating cycles max.	2 Hz
Permitted ambient temperature	-25...+70°C
LED-display	Green / yellow
Protective circuit	Built-in
Degree of protection IEC 60529	IP68
Norm	EN 60947-5-2
Connection cable	2 m PVC, 3 x 0.14 mm <sup>2</sup>
Housing material	PA / PBT
Accessories (delivered with the sensor)	Teach magnet

All specifications are subject to change without notice. (14.01.2020)

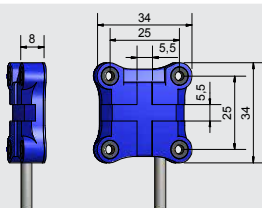
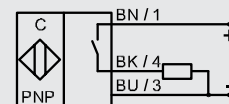

**EasyTeach chart:**  
LED / Output function  
Yellow = A1  
Green = A1

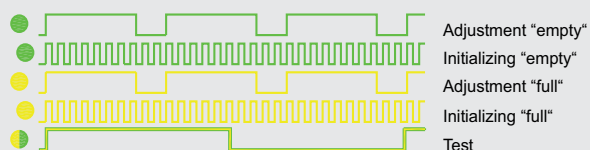

**Made in Germany**

# Capacitive Sensors **EasyMount**

- ✓ for level control of liquids
- ✓ for leakage detection

These small sensors have all that makes the handling and application easy for the user.

**The mounting is really simple.** The sensor itself is featured with excellent technical characteristics and is very small in size. It can be mounted in various ways. It can be glued in the desired position, fixed with a cable tie or it can be mounted with one of the holders from the range accessories.

The sensitivity- or sensing distance adjustment is almost made by itself, thanks to the **EasyTeach function**. In the course of which it does not matter if the magnet is used or the version with EasyTeach by wire is the model of choice. The steps one has to pass through are easy and quick to complete, so the user does not lose time from looking after his core business.

With the use of the newest production technologies the components of the sensors are embedded in the plastic body. They are watertight and operate wear-free. All sensors produced from RECHNER Sensors Germany are 100 % tested. The product marking is made with modern laser technology for everlasting identification and traceability.

For further information about Rechner Sensors feel free to contact us or visit our web site under [www.rechner-sensors.com](http://www.rechner-sensors.com).

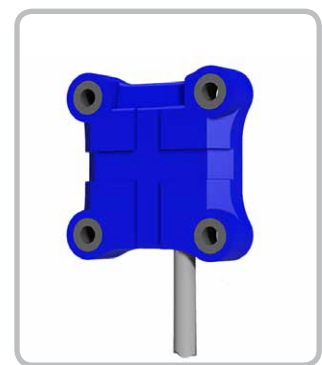
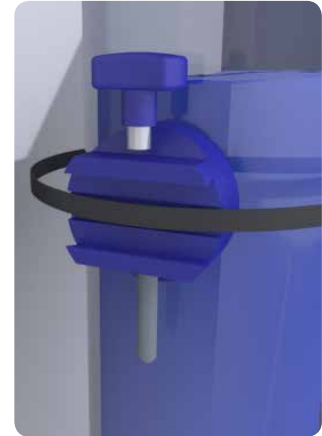

Measurement through non-metallic container walls



**EasyTeach + EasyMount  
= Simply perfect**

**IP68**

*100 % tested*  
*Laser product marking*

**Made in Germany**

All specifications are subject to change without notice. (14.01.2020)

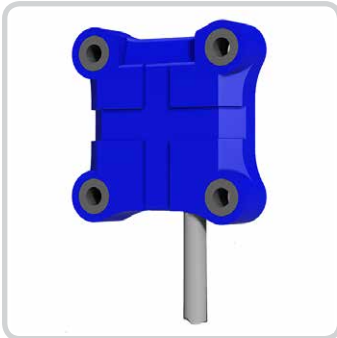

## Capacitive Sensors Series 80 - PNP **EasyMount**

- Housing 34 x 34 mm  
Capacitive sensor for level control of liquids or bulk material  
Very suitable for a measurement through non-metallic container walls
- Sensitivity adjustment with EasyTeach by wire (ETW)
  - Housing material: PA / PVC
  - Easy to mount, by screwing, glueing or with cable ties
  - Watertight
  - Flat housing - 8 mm



Technical data	Flush mountable
Operating distance $S_n$	5 mm
Operating distance min. / max. programmable	0...10 mm
Electrical version	3 wire DC
Output function	Normally open
<b>Type PNP</b>	<b>KAS-80-C30EM/8-S-34x34x8-PA-Z02-ETW-HP</b>
<b>Art.-No.</b>	<b>KA 1450</b>
Operating voltage ( $U_b$ )	10...35 V DC
Voltage drop max. ( $U_d$ )	≤ 2.0 V
Permitted residual ripple max.	10 %
Operating current ( $I_e$ )	0...200 mA
No-load current ( $I_o$ )	Typ 15 mA
Frequency of operating cycles max.	2 Hz
Permitted ambient temperature	-25...+70°C
LED-display	Green / yellow
Protective circuit	Built-in
Degree of protection IEC 60529	IP68
Norm	EN 60947-5-2
Connection cable	2 m PVC, 3 x 0.14 mm <sup>2</sup>
Housing material	PA / PVC

All specifications are subject to change without notice. (14.01.2020)

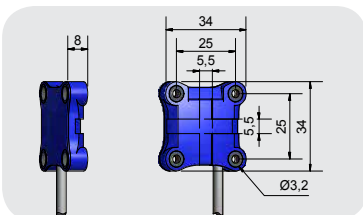
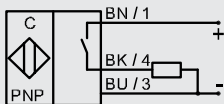

**EasyTeach chart:**  
LED / Output function  
Yellow = A1  
Green = A1

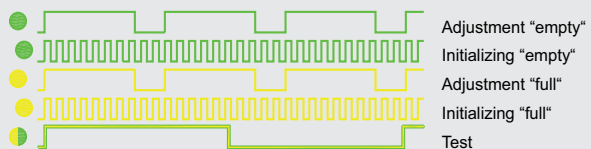

**Made in Germany**

# Capacitive Sensors **EasyMount**

- ✓ for level control of liquids
- ✓ for level control of bulk material
- ✓ for leakage detection
- ✓ for position control of objects ... and much more.

These small sensors have all that makes the handling and application easy for the user.

**The mounting is really simple.** The sensor itself is featured with excellent technical characteristics and is very small in size. It can be mounted in various ways. It can be glued in the desired position, fixed with a cable tie or it can be mounted with one of the holders from the range accessories.

The sensitivity- or sensing distance adjustment is almost made by itself, thanks to the **EasyTeach function**. In the course of which it does not matter if the magnet is used or the version with EasyTeach by wire is the model of choice. The steps one has to pass through are easy and quick to complete, so the user does not lose time from looking after his core business.

With the use of the newest production technologies the components of the sensors are embedded in the plastic body. They are watertight and operate wear-free. All sensors produced from RECHNER Sensors Germany are 100 % tested. The product marking is made with modern laser technology for everlasting identification and traceability.

For further information about Rechner Sensors feel free to contact us or visit our web site under [www.rechner-sensors.com](http://www.rechner-sensors.com).

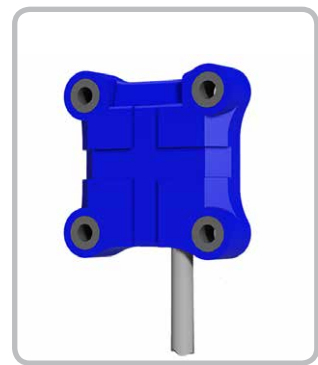
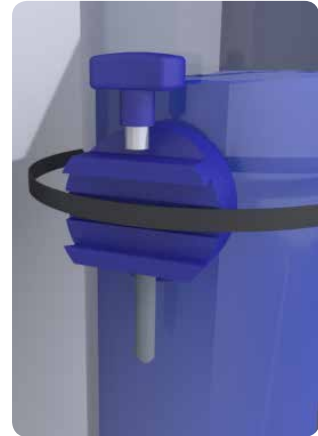

Measurement through non-metallic container walls

**IP68**

**EasyTeach + EasyMount  
= Simply perfect**

*100 % tested*

*Laser product marking*

**Made in Germany**

All specifications are subject to change without notice. (14.01.2020)

## LevelMaster - Capacitive Sensors - S26 - Analogue Output 4 - 20 mA



Model G 1/2"

- For level control of conductive and/or viscous liquids or pastes, for instance oil, water, ketchup or honey.
- Ideal for level control in the Food Industry or Pharmaceutical Industry
- Housing material: Stainless steel VA No. 1.4305 (AISI 303)
- Adjustment of the sensitivity with ETW- Function (EasyTeach by Wire)
- With flange connector M 12 x 1
- Welding sockets and Varivent adapter available for EHEDG conform mounting.
- With programmable analogue output 4 - 20 mA



Technical data	Non-flush mountable
Sensitivity	Dielectric constant $\epsilon_r > 1.25$
Electrical version	3-pin DC
Output function	Analogue
<b>Typ Analogue</b>	<b>KS-801-26/86-IL4-G1/2-PEEK/VAb-Y3-ETW-HP</b>
<b>Art. No.</b>	<b>KA 1473</b>
Operating voltage ( $U_b$ )	12.5...35 V DC
Output signal	4...20 mA
Output current active surface free	$\leq 4$ mA
Output current active surface covered	$\geq 20$ mA
Load resistor ( $R_L$ )	0...600 Ohm
No-load current ( $I_0$ )	Typ. < 30 mA
Permitted ambient temperature	0...+70 °C / CIP 121 °C
Permitted product temperature	0...+100 °C
LED-display	Green / orange
Protective circuit	Built-in
Degree of protection IEC 60529	IP 67, IP 69K
Norm	EN 60947-5-2, EN 60947-5-7*
Connection	Connector M 12 x 1
Operating pressure	Max. 10 bar
Housing material	Stainless steel VA No. 1.4305 / AISI 303
Material active surface	PEEK (FDA 21 CFR 177.2415)

**Accessories** (not supplied with the sensor): Varivent Adapter art.No. 196395, Welding Socket art.No. 196394 and matching connectors please see our selection of accessories.

Capacitive Sensors of the S26 series with hemispherical active surface for analogue level control of products with a dielectric constant  $\epsilon_r$  from 1,25. Products such as:

- Liquids, like, juice, wine, oil, chemicals or pharmaceutical solutions and much more.

### Highlights:

- EHEDG conform
- Applicable for quality control
- Permitted pressure on the active area: 10 bar

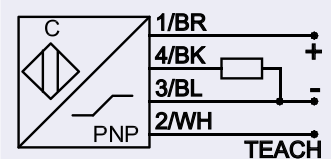

\*Where applicable

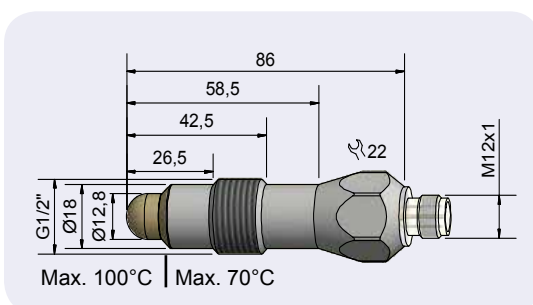

### EasyTeach chart:





# LevelMaster



This capacitive sensor is designed for the analogue level control of liquid or viscous products, which can be conductive and/or viscous and sticky.

Materials like ketchup, mayonnaise, yoghurt, syrups, pastes, or liquids with salt or acids will be reliably detected with the LevelMaster.



It could not be easier.

The user mounts the sensor, makes the electrical connection and the adjustment by means of the teach wire and the sensor is ready for use.

No additional teach equipment necessary.

Optical guidance during the teach process with the aid of a 2-colour LED:

- standby • teach process • switching state

The modern micro controller controlled temperature compensation provides for reliable level control with applications where there are variations in the ambient temperatures.

The sensor body is made of stainless steel material No. 1.4305 (AISI 303).

When the sensor is mounted with our adapters: welding socket or the process adapter Varivent N DN 50 a hygienic, EHEDG conforming process connection will be achieved.

## Directive (EC) 1935/2004

The traceability of the used plastic material PEEK according to the directive (EC) 1935/2004 is confirmed by RECHNER with a conformity declaration, that is provided on the website as download document under certificates.

## Applications

Depending on the selected type, the analogue LevelMaster can be used to carry out an analogue fill level measurement across a defined range.



At the same time, it is also possible to detect any signs of pollution so that a cleaning process can be triggered. Another application option is a display of the change in the dielectric constant (DC) of the product to be monitored for quality control. For quality control purposes, the empirically determined starting values can be controlled and analysed using for example a PLC.

In the case of applications with changing media, the empirically determined output can be programmed by the following control system: product A = analogue value X, product B = analogue value Y, product C = analogue value Z, etc.

If the product is changed, simply select the corresponding program in the PLC.

**Made in Germany**

All specifications are subject to change without notice. (14.01.2020)

## LevelMaster - Capacitive Sensors - S26 - Analogue Output 4 - 20 mA



Model G 1/2"

- For level control of conductive and/or viscous liquids or pastes, for instance oil, water, ketchup or honey.
- Ideal for level control in the Food Industry or Pharmaceutical Industry
- Housing material: Stainless steel VA No. 1.4305 (AISI 303)
- Adjustment of the sensitivity with ETW- Function (EasyTeach by Wire)
- With flange connector M 12 x 1
- Welding sockets and Varivent adapter available for EHEDG conform mounting.
- With programmable analogue output 4 - 20 mA



Technical data	Non-flush mountable
Sensitivity	Dielectric constant $\epsilon_r > 1.25$
Electrical version	3-pin DC
Output function	Analogue
<b>Typ Analogue</b>	<b>KS-801-26/133-IL4-G1/2-PEEK/VAb-Y3-ETW-HP</b>
<b>Art. No.</b>	<b>KA 1474</b>
Operating voltage ( $U_b$ )	12.5...35 V DC
Output signal	4...20 mA
Output current active surface free	$\leq 4$ mA
Output current active surface covered	$\geq 20$ mA
Load resistor ( $R_L$ )	0...600 Ohm
No-load current ( $I_0$ )	Typ. < 30 mA
Permitted ambient temperature	0...+70 °C / CIP 121 °C
Permitted product temperature	0...+100 °C
LED-display	Green / orange
Protective circuit	Built-in
Degree of protection IEC 60529	IP 67, IP 69K
Norm	EN 60947-5-2, EN 60947-5-7*
Connection	Connector M 12 x 1
Operating pressure	Max. 10 bar
Housing material	Stainless steel VA No. 1.4305 / AISI 303
Material active surface	PEEK (FDA 21 CFR 177.2415)
<b>Accessories</b> (not supplied with the sensor): Varivent Adapter art.No. 196395, Welding Socket art.No. 196394 and matching connectors please see our selection of accessories.	

Capacitive Sensors of the S26 series with hemispherical active surface for analogue level control of products with a dielectric constant  $\epsilon_r$  from 1,25. Products such as:

- Liquids, like, juice, wine, oil, chemicals or pharmaceutical solutions and much more.

### Highlights:

- EHEDG conform
- Analogue measuring range max. 40 mm
- Permitted pressure on the active area: 10 bar

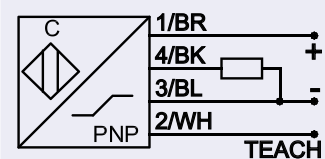

\*Where applicable

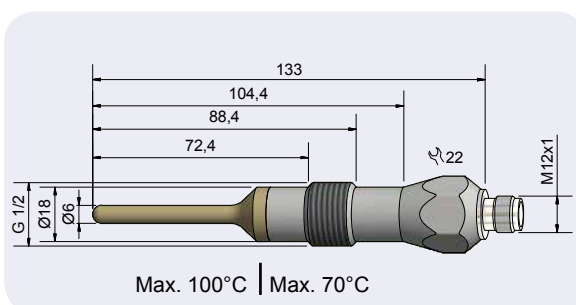

### EasyTeach chart:



**Made in Germany**



# LevelMaster

This capacitive sensor is designed for the analogue level control of liquid or viscous products, which can be conductive and/or viscous and sticky.

Materials like ketchup, mayonnaise, yoghurt, syrups, pastes, or liquids with salt or acids will be reliably detected with the LevelMaster.



It could not be easier.

The user mounts the sensor, makes the electrical connection and the adjustment by means of the teach wire and the sensor is ready for use.

No additional teach equipment necessary.

Optical guidance during the teach process with the aid of a 2-colour LED:

- standby • teach process • switching state

The modern micro controller controlled temperature compensation provides for reliable level control with applications where there are variations in the ambient temperatures.

The sensor body is made of stainless steel material No. 1.4305 (AISI 303).

When the sensor is mounted with our adapters: welding socket or the process adapter Varivent N DN 50 a hygienic, EHEDG conforming process connection will be achieved.

## Directive (EC) 1935/2004

The traceability of the used plastic material PEEK according to the directive (EC) 1935/2004 is confirmed by RECHNER with a conformity declaration, that is provided on the website as download document under certificates.

## Applications

Depending on the selected type, the analogue LevelMaster can be used to carry out an analogue fill level measurement across a defined range.

At the same time, it is also possible to detect any signs of pollution so that a cleaning process can be triggered. Another application option is a display of the change in the dielectric constant (DC) of the product to be monitored for quality control. For quality control purposes, the empirically determined starting values can be controlled and analysed using for example a PLC.

In the case of applications with changing media, the empirically determined output can be programmed by the following control system: product A = analogue value X, product B = analogue value Y, product C = analogue value Z, etc.

If the product is changed, simply select the corresponding program in the PLC.



**Made in Germany**

All specifications are subject to change without notice. (14.01.2020)



## L&V&L Capacitive Filling Level Probe - KFI

Voltage output analogue 10...0 V

- Integrated evaluation electronics
- Easy Teach by wire
- Voltage output 10 V = min. level / 0 V = max. level
- Housing material: PTFE / Aluminium
- Process connection M 12 x 1



Technical data	
Active zones [mm]	35 mm, related on the probe tip
Electrical version	5-wire DC
Output function	Analogue
<b>Type</b>	<b>KFI-1-41-35-PTFE/AL-D10-M12-UL10-ETW-Z02</b>
<b>Art.-No.</b>	<b>KI 0046</b>
Operating voltage (U <sub>B</sub> )	15...30 V DC
Permitted residual ripple max.	5 %
Load resistance (R <sub>L</sub> )	≥ 2 kΩ
Power consumption (outputs no-load)	0,9 W
Analogue output	10...0 V
Permitted ambient temperature (for active zone)	-25...+70 °C
LED-Display	Green
Protective circuit	Built-in
Degree of protection IEC 60529	IP 67
Norm	EN 60947-5-2*
Connection cable	2 m, PVC, 5 x 0.34 mm <sup>2</sup>
Housing material	Aluminium
Active zone	PTFE (FDA 21 CFR 177.1550)
Lid	PC (FDA 21 CFR 177.1580)

\*Where applicable

All specifications are subject to change without notice. (14.01.2020)

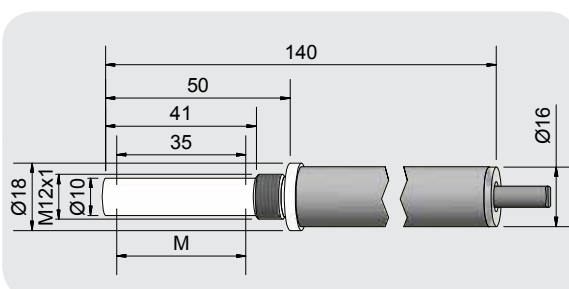

EasyTeach chart:  
LED green / Adjustment function

- [Sine wave] Adjustment Min.
- [Square wave] Adjustment Max.
- [Pulse] Factory set
- [Square wave] Test

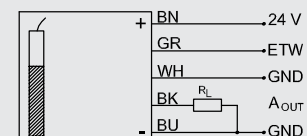

**Made in Germany**



## i-LEVEL Capacitive Filling Level Probe Analogue current output 20...4 mA

- Integrated evaluation electronics
- EasyTeach by Wire
- Current output 20 mA = min. level / 4 mA = max. level
- Housing material: PTFE / Stainless steel VA No. 1.4305 / AISI 303
- Process connection G 1/2"



Technical data	
Active zones [M]	25 mm
Electrical version	5-wire DC
Output function	Analogue
<b>Type</b>	<b>KFI-1-49-25-PTFE/VA b-D10-G1/2-IL20-ETW-Z02</b>
<b>Art.-No.</b>	<b>KI 0124</b>
Operating voltage (U <sub>B</sub> )	15...30 V DC
Permitted residual ripple max.	5 %
Load resistance (R <sub>L</sub> )	≤ 200 Ω
Power consumption (outputs no-load)	0,9 W
Analogue output	20...4 mA
Permitted ambient temperature	-25...+70 °C
LED-Display	Green
Protective circuit	Built-in
Degree of protection IEC 60529	IP 67
Norm	EN 60947-5-2*
Connection cable	2 m, PVC, 5 x 0.34 mm <sup>2</sup>
Housing material	Stainless steel VA No 1.4305 / AISI 303
Active zone	PTFE (FDA 21 CFR 177.1550)
Lid	PC (FDA 21 CFR 177.1580)

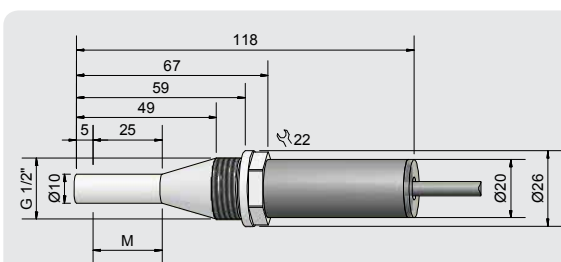

EasyTeach chart:  
LED green / Adjustment function

- Adjustment Min.
- Adjustment Max.
- Factory set
- Test

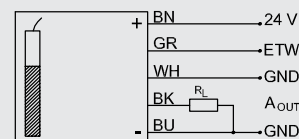

\*Where applicable

**Made in Germany**



## L&V8 Capacitive Filling Level Probe - KFI

Voltage output analogue 0...10 V

- Integrated evaluation electronics
- Easy Teach by wire
- Voltage output 0 V = min. level / 10 V = max. level
- Housing material: PTFE / Aluminium
- Process connection M 12 x 1



Technical data	
Active zones [M]	61 mm
Electrical version	4-wire DC
Output function	Analogue
<b>Type</b>	<b>KFI-1-67-61-PTFE/AL-D10-M12-UL0-ETW-Z02</b>
<b>Art.-No.</b>	<b>KI 0125</b>
Operating voltage ( $U_B$ )	15...30 V DC
Permitted residual ripple max.	5 %
Load resistance ( $R_L$ )	$\geq 2 \text{ k}\Omega$
Power consumption (outputs no-load)	0,9 W
Analogue output	0...10 V
Permitted ambient temperature	-25...+70 °C
LED-Display	Green
Protective circuit	Built-in
Degree of protection IEC 60529	IP 67
Norm	EN 60947-5-2*
Connection cable	2 m, PVC, 5 x 0.34 mm <sup>2</sup>
Housing material	Aluminium
Active zone	PTFE (FDA 21 CFR 177.1550)
Lid	PC (FDA 21 CFR 177.1580)

All specifications are subject to change without notice. (14.01.2020)

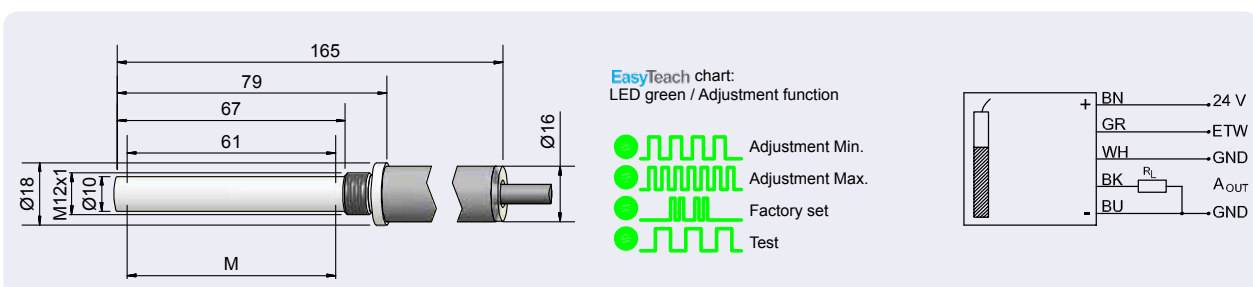

\*Where applicable

**Made in Germany**



## i-LEVEL Capacitive Filling Level Probe - KFI 1 Limit value switching point

Housing: Ø 16 mm

- Integrated evaluation electronics
- Easy Teach by Wire
- Housing material: VA No. 1.4305 / AISI 303
- Automatic identification of NPN / PNP function



### Technical data

Active zone [M]	10 mm
Electrical version	4 - Wire DC
Output function	1 limit value switching point, normally open
<b>Type</b>	<b>KFI-51-115-10-PTFE/VA-D10-D16-S-ETW-Z02</b>
<b>Art.-No.</b>	<b>KI 0102</b>
Operating voltage (U <sub>B</sub> )	15...30 V DC
Permitted residual ripple max.	5 %
Output current max.	100 mA
Power consumption (outputs no-load)	0,9 W
Frequency of operating cycles max.	1 Hz
Permitted ambient temperature	-25...+70 °C
LED-Display	Green (standby) / yellow (switching function)
Protective circuit	Built-in
Degree of protection IEC 60529	IP 67
Norm	EN 60947-5-2*
Connection cable	2 m, PVC, 5 x 0.34 mm <sup>2</sup>
Housing material	VA 1.4305 / AISI 303
Active zone	PTFE (FDA 21 CFR 177.1550)
Lid	PC (FDA 21 CFR 177.1580)

\*Where applicable

### EasyTeach chart:

LED green / Adjustment function

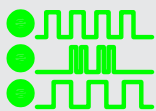

Adjustment  
Factory set  
Test

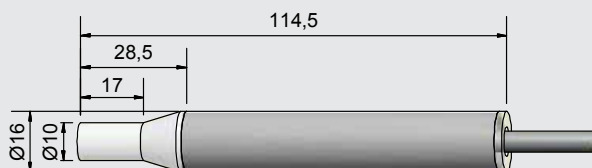
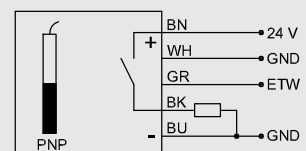
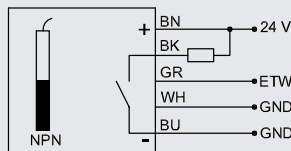

**Made in Germany**

All specifications are subject to change without notice. (14.01.2020)



## i-LEVEL Capacitive Filling Level Probe - KFI 1 Limit value switching point

- Integrated evaluation electronics
- Easy Teach by Wire
- Housing material: Aluminium
- Process connection G 1/2"
- Automatic identification of NPN / PNP function



### Technical data

Active zone [M]	35 mm
Electrical version	4-wire DC
Output function	1 limit value switching point, normally open
<b>Type</b>	<b>KFI-51-136-35-PTFE/AL-D10-M12-S-ETW-Z01</b>
<b>Art.-No.</b>	<b>KI 0052</b>
Operating voltage (U <sub>B</sub> )	15...30 V DC
Permitted residual ripple max.	5 %
Output current max.	0...100 mA
Power consumption (outputs no-load)	0,9 W
Frequency of operating cycles max.	1 Hz
Permitted ambient temperature	-25...+70 °C
LED-Display	Green
Protective circuit	Built-in
Degree of protection IEC 60529	IP 67
Norm	EN 60947-5-2*
Connection cable	1 m, PVC, 5 x 0.34 mm <sup>2</sup>
Housing material	Aluminium
Active zone	PTFE (FDA 21 CFR 177.1550)
Lid	PC (FDA 21 CFR 177.1580)

\*Where applicable

All specifications are subject to change without notice. (14.01.2020)

### EasyTeach chart:

LED green / Adjustment function

- Adjustment
- Factory set
- Test

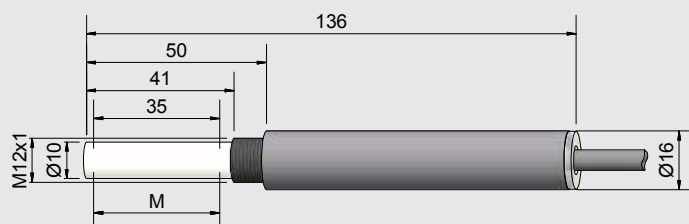
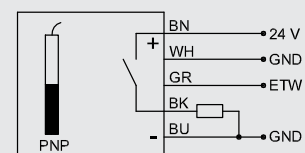
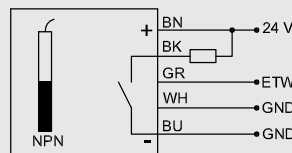

Made in Germany





## i-LeV&L Capacitive Filling Level Probe - KFI 1 Limit value switching point

- Integrated evaluation electronics
- Easy Teach by Wire
- Housing material: PTFE / VA No. 1.4305 / AISI 303
- Process connection G 1/2"
- Automatic identification of NPN / PNP function



### Technical data

Active zone [M]	25 mm
Electrical version	4-wire DC
Output function	1 limit value switching point, normally open
<b>Type</b>	<b>KFI-51-49-25-PTFE/VAb-D10-G1/2-S-ETW-Z02</b>
<b>Art.-No.</b>	<b>KI 0159</b>
Operating voltage ( $U_b$ )	15...30 V DC
Permitted residual ripple max.	5 %
Output current max.	0...100 mA
Power consumption (outputs no-load)	0,9 W
Frequency of operating cycles max.	1 Hz
Permitted ambient temperature	-25...+70 °C
LED-Display	Green
Protective circuit	Built-in
Degree of protection IEC 60529	IP 67
Norm	EN 60947-5-2*
Connection cable	2 m, PVC, 5 x 0.34 mm <sup>2</sup>
Housing material	VA No 1.4305 / AISI 303
Active zone	PTFE (FDA 21 CFR 177.1550)
Lid	PC (FDA 21 CFR 177.1580)

\*Where applicable

### EasyTeach chart:

LED green / Adjustment function

- Adjustment
- Factory set
- Test

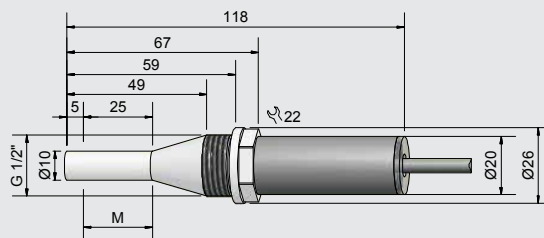
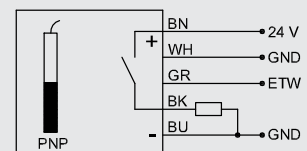
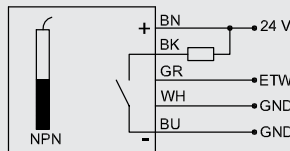

Made in Germany

All specifications are subject to change without notice. (14.01.2020)



## i-LEVEL Capacitive Filling Level Probe Analogue current output 20...4 mA

- Integrated evaluation electronics
- EasyTeach by Wire
- Current output 20 mA = min. level / 4 mA = max. level
- Housing material: POM
- Blanking plug in stainless steel VA No. 1.4305 (AISI 303)



### Technical data

Active zones [M]	210 mm
Electrical version	5-wire DC
Output function	Analogue
<b>Type</b>	<b>KFI-1-300-210-POM-D16-IL-20-ETW-Z02</b>
<b>Art.-No.</b>	<b>KI0150</b>
Operating voltage (U <sub>B</sub> )	15...30 V DC
Permitted residual ripple max.	5 %
Load resistance (R <sub>L</sub> )	≤ 200 Ω
Power consumption (outputs no-load)	0,9 W
Analogue output	20...4 mA
Permitted ambient temperature	-25...+70 °C
LED-Display	Green
Protective circuit	Built-in
Degree of protection IEC 60529	IP 67
Norm	EN 60947-5-2*
Connection cable	2 m, PVC, 5 x 0.34 mm <sup>2</sup>
Housing material blanking plug	VA No. 1.4305 / AISI 303
Active zone	POM
Lid	PC (FDA 21 CFR 177.1580)

**Accessories** for mounting (not delivered with the probe) please see our selection of accessories.

All specifications are subject to change without notice. (14.01.2020)



### EasyTeach chart:

- LED green / Adjustment function
- [Sine wave] Adjustment Min.
  - [Square wave] Adjustment Max.
  - [Pulse] Factory set
  - [Sine wave] Test

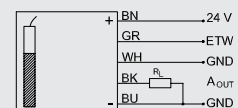

\*Where applicable

**Made in Germany**



## Customer proximity guaranteed!

Rechner Sensors has daughter and sister companies in China, Great Britain, Italy, Canada, South Korea and in the U.S..

Furthermore we have representative offices in over 50 countries. For the addresses of our sales partners please visit our website. You will find the addresses under the category contact.

### CANADA

**Rechner Automation Inc**  
348 Bronte St. South - Unit 11  
Milton, ON L9T 5B6

Tel. 905 636 0866  
Fax. 905 636 0867  
contact@rechner.com  
www.rechner.com

### GREAT BRITAIN

**Rechner (UK) Limited**  
Unit 6, The Old Mill  
61 Reading Road  
Pangbourne, Berks, RG8 7HY

Tel. +44 118 976 6450  
Fax. +44 118 976 6451  
info@rechner-sensors.co.uk  
www.rechner-sensors.co.uk

### ITALY

**Rechner Italia SRL**  
Via Isarco 3  
39100 Bolzano (BZ)  
Office:  
Via Dell'Arcoveggio 49/5  
40129 Bologna  
Tel. +39 051 0015498  
Fax. +39 051 0015497  
vendite@rechneritalia.it  
www.rechneritalia.it

### PEOPLE'S REPUBLIC OF CHINA

**RECHNER SENSORS SIP CO.LTD.**  
Building H,  
No. 58, Yang Dong Road  
Suzhou Industrial Park  
Jiangsu Province

Tel. +8651267242858  
Fax. +8651267242868  
assist@rechner-sensor.cn  
www.rechner-sensor.cn

### REPUBLIC OF KOREA (SOUTH)

**Rechner-Korea Co. Ltd.**  
A-1408 Ho,  
Keumgang Penterium IT Tower,  
Hakeuro 282, Dongan-gu  
Anyang City, Gyunggi-do, Seoul

Tel. +82 31 422 8331  
Fax. +82 31 423 83371  
sensor@rechner.co.kr  
www.rechner.co.kr

### UNITED STATES OF AMERICA

**Rechner Electronics Ind. Inc.**  
6311 Inducon Corporate Drive,  
Suite 5  
Sanborn, NY. 14132

Tel. 800 544 4106  
Fax. 905 636 0867  
contact@rechner.com  
www.rechner.com



All specifications are subject to change without notice. (14.01.2020)

# RECHNER

**INDUSTRIE-ELEKTRONIK GMBH**

**Gaußstraße 6-10 • 68623 Lampertheim • Germany**

T: +49 6206 5007-0 • F: +49 6206 5007-36 • F Intl. +49 6206 5007-20

[www.rechner-sensors.com](http://www.rechner-sensors.com) • E-mail: [info@rechner-sensors.de](mailto:info@rechner-sensors.de)